

KDE81LC Multifunction meter

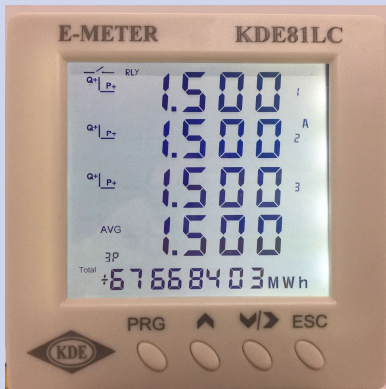













Multifunction meter type LCD model KDE81LC
SPECIFICATIONS

DISPLAY	Parameter display
Liquid crystal display with backlight (LCD)	Voltage phase-phase: 1-2
4 lines, 4 digits per line to show electrical parameters	2-3
5th line, 8 digits to show energy	3-1
Coordinate axis define the working domain	Voltage line average
Programable CT (primary/secondary)	Voltage phase – neutral
Programable PT (primary/secondary)	Phase 1
Measurement true RMS	Phase 2
Password protect(program, clear energy)	Phase 3
Relay output programable	Voltage line-neutral average
Communication RS485, Modbus RTU	Current
Resolution automatic	Current phase 1
Auxiliary Supply	Current phase 2
Network connection 3P4W, 3P3W 1P2W	Current phase 3
Update data 1 second	Current average
Time display 2.5, 5, 7.5 second	Power factor
	Phase 1
	Phase 2
	Phase 3
	Power factor average
	Active power (kW)
	Phase 1
	Phase 2
	Phase 3
	Total active power 3 phase
	Reactive power (kVAr)
	Phase 1

Parameter display	
Phase 2	Import Maxdemand
Phase 3	Export Maxdemand
Total reactive power 3 phase	Active energy import kWh
Apparent (kVA)	Reactive energy import kVArh
Phase 1	Active energy export kWh
Phase 2	Reactive energy export kVArh
Phase 3	Apprent energy kVAh
Total apparent power 3 phase	Load hours import
Frequency Hz	Load hours export
Phase voltage - voltage	Total load hours
Phase voltage – current	Counter on meter

SPECIFICATIONS	
Input network	3P3W, 3P4W, 1P2W
Input voltage	30-300V (L-N) ; 50-500V (L-L)
Input current	7.5mA – 6A
Input load	0.3VA / channel (voltage/current)
Auxiliary Supply	90-270VAC/DC, 8VA
Display	4x4 rows, 8x1 rows, LCD.
Method measure	True RMS.
Time update data	1 sec
Frequency	45-65Hz
Temperature Operating	-10~55° C
Storage Temperature	-20 to 75C
Humidity	< 95 % (non condensing)
Environmental user	Indoor
Altitude of up to	1000m
Protection Level	IP 65 (for faceplate)
Pulse output	Max voltage 24VDC
Width pulse	Range 1 là $T \geq 160ms$, $T_p = 80ms$, Range 2 là $10ms \leq T < 160ms$, $T_p = T/2$ (Depend on power and number pules)
Relay output	5A-250VAC, COM-NO-NC (programable)
Weight	350Gram
Dimensions	96x96x70.99 mm (LxDxW)
Panel cut out	(91)mm X (91) mm
Mounting	Panel mount, keep by 4 clamp in corner

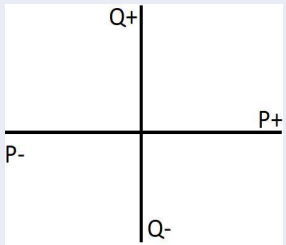
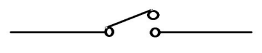
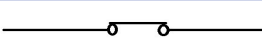
LCD - Display	Mean
AVG	Average Value
Σ	Total value
DMD	Demand value
Total	Total value energy
Total Net	Total value energy (import + export)
P1, P2, P3 +	Sign + in row energy, mean energy in phase 1, phase 2, phase 3 import
P1, P2, P3 -	Sign - in row energy, mean energy in phase 1, phase 2, phase 3 export
Total 3P +	Total 3P sign +in row energy, mean total energy import (P1+P2+P3)
Total 3P -	Total 3P sign - in row energy, mean total energy export -(P1+P2+P3)
Total Net 3P	Total net 3P equal 'total 3P +' + 'total 3P -', units kWh or kVAh
Total Net 3P	With unit kVAh, mean total apparent import + export
	Blinks after every 3 sec, meter save energy to memory
®	Blinks after every 3 sec, Communication in progress
	Import combined with I, P,S, Hour
	Export combined with I, P,S, Hour
 (Hour)	Counter total load hour import
 total load import 	Counter total load hour Export
 (Hour) 	Counter total load hour import + export
	Power Up: Counter total on meter
	PEAK: reserved
	Phi: phase angle voltage - voltage
	Phi O: phase angle voltage – current
P	Active power with unit W,kW, MW, GW
Q	Reactive power with unit VAR,kVAR, MVAR, GVAR
S	Apparent power with unit VA,kVA, MVA, GVA
	<p>P+: Import active power</p> <p>P-: Export active power</p> <p>Q+: Import reactive power, load is inductor</p> <p>Q-: Export reactive power, load is capacitor</p> <p>On 3phase system, at a time load only at 1 quadrant</p>
	Contact open
	Contact close

RESOLUTION - ACCURACY :

Parameter measure	Resolution	Value start	Value max	Time update	Error
Voltage(phase/ line)	1mV (direct)	30V (phase)	30-300V	1 sec	0.2%
Current	1mA (direct)	7.5mA	7.5mA-6A	1 sec	0.2%
Active power	10W (direct)	10W (inner meter measurement from 1.65W, with purpose kWh)		1 sec	0.2%
Reactive power	10VAr	10VAr		1 sec	0.5%
Apparent power	10VA	10VA		1 sec	1%
Energy	1Wh, 1VArh, 1VAh,	--	99999999 MWh	1 sec	(Wh class 0.5) (VArh, Vah class1) IEC-62052-11 và 62053-21
Alarm relay current	mA	--	99.999.999	--	1%
Alarm relay power	W/VA	--	99.999.999		1%
Power factor(PF)	0.001	--	+/-1	500 mili sec	+/- 0.001
Phase angle voltage - voltage	1°	0	360°	500 mili sec	+/- 1°
Phase angle voltage – current	1°	0	360°	500 mili sec	+/- 1°
Frequency	0.01Hz	45	65	500 mili sec	+/- 0.1% voltage line – neutral higher 30V



Resolution in modbus

Ratio PT x Ratio CT	kWh/kVArh/kVAh	Value on modbus*resolution
<15	10	Value on Modbus * gain => resul is kWh, kVArh, kVAh, Ex. PT: 22kV/110V, CT 10000/5 => PTXCT=200*2000=400.000=> Gain 1.000.000, register on modbus is 1,234567 => real value kWh=1,234567*1.000.000=1.234.567=> kWh=1.234.567
<150	100	
<1500	1000	
<15000	10000	
<150000	100000	
>=150000	1000000	

SERIAL COMMUNICATION KDE81LC, 85C, 61C

Interface standard and protocol	RS485 và MODBUS RTU
Communication address	1-255
Transmission mode	half duplex
Data types	Float and Integer
Transmission distance	Max 500m
Transmission Speed	300, 600, 1200, 2400, 4800, 9600 bps
Parity	None, Odd, Even
Stop bits	1 hoặc 2
Response time	100 mS (max and independent of baud rate)

Page display	Symbol	Parameter display
1	V_{L-L}	Displays line to line voltage of three phase and average line to line voltage
2	V_{L-N}	Displays line to neutral voltage of three phase and average line to neutral voltage
3	PH i	Phase angle voltage to voltage
4	A	Displays phase current of three phase and average current.
5	U, I, PF, kW Phase 1	Voltage, current, power factor, active power U, I, PF, P of phase 1
6	U, I, PF, kW Phase 2	Voltage, current, power factor, active power U, I, PF, P of phase 2
7	U, I, PF, kW Phase 3	Voltage, current, power factor, active power U, I, PF, P of phase 3
8	U, I, PF, F, AVG	Voltage, current, power factor, frequency U, I, PF, F average
9	W	Active power of three phase and total active power
10	VA _r	Reactive power of three phase and total reactive power.
11	VA	Apparent power of three phase and total apparent power
12	PF	Power factor of three phase and average power factor
13	P, Q, S, PF	P1, Q1, S1, PF1 Active, reactive, apparent power and power factor of first phase.
14	P, Q, S, PF	P2, Q2, S2, PF2 Active, reactive, apparent power and power factor of second phase
15	P, Q, S, PF	P3, Q3, S3, PF3 Active, reactive, apparent power and power factor of third phase
16	P, Q, S, PF	P, Q, S, PF Total active, reactive, apparent power and average power factor of three phase.
17	PH i °	Phi o phase angle voltage current
18	I, DMD, P	Maximun active, total active power demand import,
19	E, DMD, P	Maximun active, total active power demand export
20	E, DMD, I	Maximun current demand import,
21	I, DMD, I	Maximun current demand export
22	E, DMD, S	Maximun apparent, total apparent power demand import,
23	I, DMD, S	Maximun apparent, total apparent demand export
24	Peak	Reserved
25	I, Hour	Total load hours import
26	E, Hour	Total load hours export
27	Total, Hour	Total load hours import + export
28	P Up	Counter on meter



Using key  to change page display, using key , to return previous page display

Display Energy page









	Displays	Parameter
1	+P1 kWh	kWh: Displays active energy of first phase import
2	+P2 kWh	kWh: Displays active energy of second phase import
3	+P3 kWh	kWh: Displays active energy of third phase import
4	-P1 kWh	kWh: Displays active energy of first phase export
5	-P2 kWh	kWh: Displays active energy of second phase export
6	-P3 kWh	kWh: Displays active energy of third phase export
7	+3P kWh	kWh: Displays active energy of three phase import
8	-3P kWh	kWh: Displays active energy of three phase export
9	Total Net 3P kWh	kWh: Displays active energy of three phase Import + export
10	+P1 kVArh	kVArh: Displays reactive energy of first phase import
11	+P2 kVArh	kVArh: Displays reactive energy of second phase import
12	+P3 kVArh	kVArh: Displays reactive energy of third phase import
13	-P1 kVArh	kVArh: Displays reactive energy of first phase export
14	-P2 kVArh	kVArh: Displays reactive energy of second phase export
15	-P3 kVArh	kVArh: Displays reactive energy of third phase export
16	+3P kVArh	kVArh: Displays reactive energy of three phase import
17	-3P kVArh	kVArh: Displays active energy of three phase export
18	Total Net 3P kVArh	kVArh: Displays reactive energy of three phase Import + export
19	P1 kVAh	kVAh: Displays apparent energy of first phase
20	P2 kVAh	kVAh: Displays apparent energy of second phase
21	P3 kVAh	kVAh: Displays apparent energy of third phase
22	Total Net 3P kVAh	kVAh: Displays apparent energy of three phase

Using key  , to next display energy, in energy mode display, can't return previous display page, only press key

 to spin return.

Page	Symbol	Default	Description	Input range
1	Addr	001	Slave Id	1-255 (247)
		tYP-0	Type address register	0-1
2	Pt-P	000350	PT Primary	100V-500kV
3	Pt-S	350	PT Secondary	30-500
4	Ct-P	00005	CT Primary	1-10000A
5	Ct-S	5	CT Secondary	1 hoặc 5A
6	PUC °	PULS- COnS 10000	Pules output	150-10000
7	Clr-I	r U SUrE P 0000	Clear energy (kWh, kVArh, kVAh) import, sure clear, press pass 1001, doesn't clear press  or waiting meter escape.	1001
8	Clr-E	r U SUrE P 0000	Clear energy (kWh, kVArh, kVAh) export, sure clear, press pass 1001, doesn't clear press  or waiting meter escape.	1001
9	nPass	CHG PASS 1000	Change Password, input new password, press 	0000-9998
10	MdtY	Md-Type	Programable type relay active	0-2
		Curr	Current	0
		W	Active power	1
		VA	Apparent power	2
11	Mdit	Md-IntP 0300	Time calculate Maxdemand	1-1800 secs
12	rELA	rELY HoLt 0005	Programable hold relay, 0000 after relay active always keeping, 0001-1800 relay keep during time, after relay relax, (to reset maxdemand or power off relay will active again, or wait update max demand cycles)	0-1800 giây
13	MD-C	00005000	Programable current protect	1-99999999mA
14	MD-I	00001000	Programable power protect (Apparent, active depend on MD-Type) Import	1-99999999 W/VA
15	MD-E	00001000	(Apparent, active depend on MD-Type) Export	1-99999999 W/VA





Press  display PASS input 1000 enter page setup

	Ký hiệu	Default	Decription	Input range
16	CPdI	r U SUrE P CPdI	Clear Maxdemand Import, if you are sure clear, press  , if you aren't sure clear press  or no press anything, waiting meter automatic escape	
17	CPdE	r U SUrE P CPdE	Clear Maxdemand (Imax, Pmax, Smax) export, if you are sure clear, press  , if you aren't sure clear press  or no press anything, waiting meter automatic escape	
18	bAUd	bAUd -9600 St1 None	Programable Baud	9600
		St1-St2	Stop bit	1-2
		nOnE-Odd-EUEN	parity bits	0-1-2
19	COnt	COnt rU SUre P	Reserver	
20	CLtI	CLtI – rU Sure - P	Clear timer load hours Import (meter CLtI – rU Sure - P If you want to clear press  , you don't want clear press  Action clear timer import load hours and total load hours	
21	CLtE	CLtI - rU Sure - P	Clear timer load hours Export (meter CLtI – rU Sure - P If you want to clear press  , you don't want clear press  Action clear timer export load hours	
22	SCrL	Dis	Mode display: manual	0
		EnA1	Mode scroll display 2.5 sec	1
		EnA2	Mode scroll display 5 sec	2
		EnA3	Mode scroll display 7.5 sec	3



Màn hình	Ký hiệu	Mặc định	Mô tả	Dải đầu vào
23	bACL	ON	Back light – always light	1
		30-300	Programable backlight	30-300 300 (1=On, 0=Off, 2=30S, 3=60S, 4=120S, 5=300S)
		OFF	Back light – always off	0
24	nEtW	3P4W	Network 3P4W	0
		3P3W	Network 3P3W	1
		1P2W-1-	Network 1P2W, phase 1	2
		1P2W-2-	Network 1P2W, phase 2	3
		1P2W-3-	Network 1P2W, phase 3	4
25	Sern		Serial number, factory marking 16 digits	YYYYMMDD







Using key  to enter menu setup, using key  to escape, using up and left key, to input value and move cursor, after input value to confirm press key , press key  to cancel, to reset factory default press key , input 9999, press  to confirm. Note this command not change energy register.







DETAILED INSTALLATION INSTRUCTIONS

Select the Menu to be edited using  and  Keys and press  Keys and press, escape to setup by press key  or wait 10 sec, meter automatic escape









Key press  display shows  input 1000 press  entering setup









Menu 1: (Unit Address for RS485 communication) press  the display shows 
 001 is address, 0 is type modbus address register , (this manufacturer put 2 type address for customer choice).







Menu 2:(To set PT Primary), after completed menu 1, Key press  next menu 2, When  key press the display shows , key press  shows  000350, set up value primary voltage Examples (035000V the same as 35kV, Maximum up to 500kV), completed input press  to confirm, if you don't want save, press  or wait meter automatic escape

Manu 3: To set PT Secondary, after completed menu 2, Key press  into menu 3, When  key press display shows , key press  shows  350, set up value secondary Examples 100V, Maximum up to 500V), completed input press  to confirm, if you don't want save, press  or wait meter automatic escape.

Note: default factory is Pt-P= 000350, Pt-S=350, CT-P=5, CT-S=5







Menu 4: To set CT Primary, Key press  shows  press  shows , using   to input value request completed input press  to confirm, if you don't want save, press  or wait meter automatic

Menu 5: To set CT Primary, Key press  shows , press  shows , using  , to input value request completed input press  to confirm, if you don't want save, press  or wait meter automatic escape.

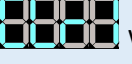

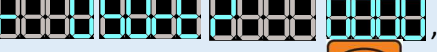



Menu 6 : To set pulse output/kWh Key press  shows , press  show , press  to value request (10000, 150, 300, 450, 600, 900, 1000, 1600, 3200, 6000.) press  to confirm, if you don't want save, press  or wait meter automatic escape.



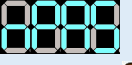

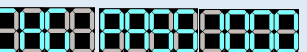



Menu 7: (To clear Import Energy) key press , show  when  is pressed the display shows , using   To input password 1001, Press  key once again to confirm clear energy, press  or wait meter automatic escape.



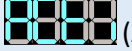

Note: active by command clear all energy register import all phase, and register total kWh, kVARh, kVAh





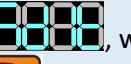
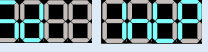

Menu 8: (To clear Export Energy) key press , show  when  is pressed the display shows , using   To input password 1001, Press  key once again to confirm clear energy, press  or wait meter automatic escape.



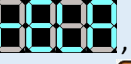

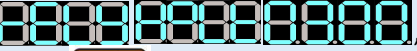



Note: active by command clear all energy register Export all phase, and register total export kWh, kVARh, kVAh









Menu 9: To set New Password press  shows  When  Key is pressed the display shows , The password can be edited using   key. After entering desired value press  key to save value. if you don't want save press  or wait meter automatic escape.









Menu 10: (To select Maximum Demand (MD) Type), press  shows , when  key is pressed the display shows , (Current), by pressing  key shows  (Active) or  (apparent) can be selected, After selecting desired type press  key to save. if you don't want save press  or wait meter automatic escape.









Menu 11: (To set MD Integration time) press  shows , when Key is pressed the display shows , The time can be edited using  &  (time is in second max 1800sec) . After entering desired value press  key to save value. if you don't want save, press  or wait meter automatic escape.







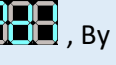

Menu 12 : (To set MD threshold relay) press  shows , when  key is pressed the display shows , The threshold can be edited using   keys. After entering desired value press  key to save value. if you don't want save, press  or wait meter automatic. Timer range from 0000-1800sec, if setup 0000 relay always keep, only relax when fault reset.







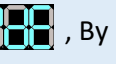







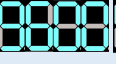
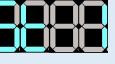

Menu 13: To setup relay active by current , press  shows , when  Key is pressed the display shows , 00005000, The current can be edited using  &  Keys. After entering desired value press  key to save value. if you don't want save, press  or wait meter automatic. Here current has unit mA, default factory is 5000mA, equal 5A, Maximum can be set 99999,999A.

Menu 14: To setup relay active by active/ apparent power import , press  shows , when  Key is pressed the display shows  00005000, the change value can be edited using  &  Keys, . After entering desired value press  key to save value. if you don't want save, press  or wait meter automatic escape

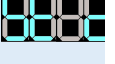







Menu 15: To setup relay active by active/ apparent power import , press  shows , when  Key is pressed the display shows  00005000, the change value can be edited using  &  Keys, . After entering desired value press  key to save value. if you don't want save, press  or wait meter automatic escape
Here active /apparent power has unit W/VA depend on Menu 10 is selected, default factory is 1000, the same 1000W/VA, maximum can set 99999999W/VA









Menu 16: (To clear MD Import (including reset current and power), press  shows  when  Key is pressed the display shows     , By pressing Key  once again the MD import will get clear. if you don't want save, press  or wait meter automatic escape









Menu 17: (To clear MD Export (including reset current and power), press  shows  when  Key is pressed the display shows     , By pressing Key  once again the MD Export will get clear. if you don't want save, press  or wait meter automatic escape

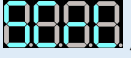







Menu 18: (To set the Baud Rate & Parity) press  shows , when  Key is pressed the display shows     , The Baud Rate for RS485 communication can be set using  Key. Using  key you can select Baud / Stop bits/Parity menu. The stop bits can be set using    The Even / odd / none ( ) parity can be set using  , After entering desired value press  key to save value. . if you don't want save, press  or wait meter automatic escape













Menu 19: Reserved



Menu 20: To Reset ON TIMER import, press  show  when  Key is pressed the display shows    , By pressing  Key once again the ON TIMER will get clear or press  Key to come out.

Menu 21: To Reset ON TIMER export, press  show  when  Key is pressed the display shows    , By pressing  Key once again the ON TIMER will get clear or press  Key to come out.

Menu 22: To select Auto / Manual Scroll) press key , show , when  Key is pressed the display shows , You can select "dis" to disable Auto scroll by select "  or  or  " to select Auto scroll using , press key  to save value. if you don't want save, press  or wait meter automatic escape

Menu 23: To set up timer back light, press key , show , when  Key is pressed the display shows , using key  to select time want to light  , to confirm press key . if you don't want save, press  or wait meter automatic escape

Menu 24: To select type network connection, press key , shows , when  Key is pressed the display shows , using  to select type  or   or  or   to confirm network type press key . if you don't want save, press  or wait meter automatic escape

Menu 25: to check serial number, press key  show , shows  when Key is pressed the display shows `YYYYMMDDLLLLxxxx`, press Key  to come out. để

Menu26: To reset default factory, from meter press key  display show  , input 9999 press 
Meter come back factory setting, only active register setup, not active energy, timer register

During user, if meter appear Err1, this is error trust initialization, and Err2, this is disconnect MCU1 with MCU2, please contact with manufacturer

Readable parameters for Communication, 4byte, ; Data Structure : Float

Address	Hex address	Parameter
30000	0x00	Voltage V1N
30002	0x02	Voltage V2N
30004	0x04	Voltage V3N
30006	0x06	Voltage V1N
30008	0x08	Voltage V12
30010	0x0A	Voltage V23
30012	0x0C	Voltage V31
30014	0x0E	Average Voltage LL
30016	0x10	Current I1
30018	0x12	Current I2
30020	0x14	Current I2
30022	0x16	Average Current
30024	0x18	kW1
30026	0x1A	kW2
30028	0x1C	kW3
30030	0x1E	kVA1
30032	0x20	kVA2
30034	0x22	kVA3
30036	0x24	kVAr1
30038	0x26	kVAr2
30040	0x28	kVAr3
30042	0x2A	Total kW
30044	0x2C	Total kVA
30046	0x2E	Total kVAr
30048	0x30	PF1
30050	0x32	PF2
30052	0x34	PF3
30054	0x36	Average PF
30056	0x38	Frequency
30058	0x3A	Total net kWh
30060	0x3C	Total net kVAh
30062	0x3E	Total net kVArh
30064	0x40	kW1 MAX Active Power import
30066	0x42	kW2 MAX Active Power import
30068	0x44	kW3 MAX Active Power import
30070	0x46	Total kW MAX average Active Power import
30072	0x48	Total kW MAX Active Power import
30080	0x50	Counter on meter
30082	0x52	Total load hours (import + export)
30084	0x54	kWh1 Import
30086	0x56	kWh2 Import
30088	0x58	kWh3 Import
30090	0x5A	kWh1 Export
30092	0x5C	kWh2 Export
30094	0x5E	kWh3 Export
30096	0x60	Total kWh 3P Import
30098	0x62	Total kWh 3P Export
30100	0x64	kVArh1 Import
30102	0x66	kVArh2 Import
30104	0x68	kVArh3 Import
30106	0x6A	kVArh1 Export

Thanh ghi truyền thông chỉ đọc, 8byte, kiểu dữ liệu float

30108	0x6C	kVArh2 Export
30110	0x6E	kVArh3 Export
30112	0x70	Total kVArh 3P Import
30114	0x72	Total kVArh 3P Export
30116	0x74	kVAh1 (Import + Export)
30118	0x76	kVAh2 (Import + Export)
30120	0x78	kVAh3 (Import + Export)
30684	0x2AC	Serial number of unit
30692	0x2B4	MAX I1 Demand import
30694	0x2B6	MAX I3 Demand import
30696	0x2B8	MAX I3 Demand import
30698	0x2BA	MAX Average (I1+I2+I3) Demand import
30700	0x2BC	Phase Sequence Indicator
30702	0x2BE	kW1 MAX Active Power Export
30704	0x2C0	kW2 MAX Active Power Export
30706	0x2C2	kW3 MAX Active Power Export
30708	0x2C4	Total kW MAX average Active Power Export
30710	0x2C6	Total kW MAX Active Power Export
30712	0x2C8	MAX I1 Demand Export
30714	0x2CA	MAX I3 Demand Export
30716	0x2CC	MAX I3 Demand Export
30718	0x2CE	MAX Average (I1+I2+I3) Demand Export
30720	0x2D0	Reserve
30722	0x2D2	Reserve
30724	0x2D4	Reserve
30726	0x2D6	Reserve
30728	0x2D8	Total MAX Reactive Power Import
30730	0x2DA	Reserve
30732	0x2DC	Reserve
30734	0x2DE	Reserve
30736	0x2E0	Reserve
30738	0x2E2	Total MAX Reactive Power Export
30740	0x2E4	kVA1 MAX Apparent Power Import
30742	0x2E6	kVA2 MAX Apparent Power Import
30744	0x2E8	kVA3 MAX Apparent Power Import
30746	0x2EA	Reserve
30748	0x2EC	Total kVA Max Apparent Power Import
30750	0x2EE	kVA1 MAX Apparent Power Export
30752	0x2F0	kVA2 MAX Apparent Power Export
30754	0x2F2	kVA3 MAX Apparent Power Export
30756	0x2F4	Reserve
30758	0x2F6	Total kVA Max Apparent Power Export
30760	0x2F8	Load hours import
30762	0x2FA	Load hours export
30764	0x2FC	Phase angle voltage phase 1 phase 1
30766	0x2FE	Phase angle voltage phase 1 phase 2
30768	0x300	Phase angle voltage phase 1 phase 3
30770	0x302	Phase angle voltage – current phase 1
30772	0x304	Phase angle voltage – current phase 2
30774	0x306	Phase angle voltage – current phase 2
30776	0x308	Relay status

Readable / writable parameters

Address	Hex Address	Parameter	Display range		Data Structure + Length (register)
			Min	Max	
40000	0x00	Password	0000	9998	(Int) 1
40001	0x01	Network connection	0	4	(Int) 1
		Application LCD + LED	0	3P4W	(Int) 1
		Application LCD + LED	1	3P3W	(Int) 1
		Application LCD + LED (user general)	2	1P2W-P1	(Int) 1
		Application LCD	3	1P2W-P2	(Int) 1
		Application LCD	4	1P2W-P3	(Int) 1
40002	0x02	CT Secondary (A)	1	5	(Int) 1
40003	0x03	CT Secondary (A)	1	10000	(Int) 1
40004	0x4	PT Secondary (V)	100	500	(Int) 1
40005	0x05	PT primary (V)	100	500.000	(Int) 1
40007	0x07	Slave id	1	255	(Int) 1
			Value	Means	
40008	0x08	Baud rate (bps)	0x0000	300	(Int) 1
			0x0001	600	
			0x0002	1200	
			0x0003	2400	
			0x0004	4800	
			0x0005	9600	
			Value	Means	
40009	0x09	Parity	0x0000	None	(Int) 1
			0x0001	Odd	
			0x0002	Even	
			Value	Means	
40010	0x0A	Stop Bit	0x0000	1	(Int) 1
			0x0001	2	
40011	0x0B	Backlight OFF (sec.)	0	300 (1=On, 0=Of, 2=30S, 3=60S, 4=120S, 5=300S)	(Int) 1
40012	0x0C	Factory Default	9999	Factory reset	(Int) 1
40013	0x0D	Reset kWh	1	Clear total import, export, Import + export	(Int) 1
40014	0x0E	Reset kVAh	1	The same as kWh	(Int) 1
40015	0x0F	Reset kVArh	1	The same as kWh	(Int) 1
40016	0x10	Reserve	1		(Int) 1

Readable / writable parameters (continous)

40037	0x25	Reset MAX kW Import	1		(Int) 1
40038	0x26	Reset MAX kW Import	1		(Int) 1
40039	0x27	Reset MAX kVAr Import	1		(Int) 1
40030	0x28	Reset MAX kVAr Export	1		(Int) 1
40041	0x29	Reset MAX kVA Import	1		(Int) 1
40042	0x2A	Reset MAX kVA Export	1		(Int) 1
40043	0x2B	Reset total Load hour	1		(Int) 1
40044	0x2C	Reset counter on meter	1		(Int) 1
			Value	Mean	
40058	0x3A	Programable pules output/ kWh	9	0: 150; 1: 300; 2: 450; 3: 600; 4: 900; 5: 1000; 6: 1600; 7: 32008: 6000; 9: 10000	(Int) 1
40064	0x40	Reset MAX Current import	1		(Int) 1
40065	0x41	Reset MAX Current Export	1		(Int) 1
40066	0x42	Reset Load hour import	1		(Int) 1
40067	0x43	Reset Load hour export	1		(Int) 1
			Value	Means	
40068	0x44	Programable relay action protect	0x0000	Current	(Int) 1
			0x0001	Active power kW	
			0x0002	Apparent power kVA	
40069	0x45	Programable timer calculate max demand	0000	1800	(Int) 1
40071	0x47	Programable max kW/kVA Import	0000	9999,9999	(Int) 1
40073	0x49	Programable max kW/kVA Export	10	9999,9999	(Int) 1
40075	0x4B	Programable max Current	10	9999,9999	(Int) 1
40077	0x4D	Serial number of units	0000	16 digits	(Int) 1
40085	0x55	Display mode	0x0000	Dis (Manual)	(Int) 1
			0x0001	EnA1 (Fast)	(Int) 1
			0x0002	EnA2 (Average)	(Int) 1
			0x0003	EnA3 (Slow)	(Int) 1
40086	0x56	Timer keep relay	0000	1800	(Int) 1

SAFETY PRECAUTIONS All safety related codifications, symbols and instructions that appear in this operating manual or on the equipment must be strictly followed to ensure the safety of the operating personnel as well as the instrument. If the equipment is not used in a manner specified by the manufacturer it might impair the protection provided by the equipment. Do not use the equipment if there is any mechanical damage. Ensure that the equipment is supplied with correct voltage.

1. Read complete instructions prior to installation and operation of the unit.
2. Risk of electric shock.
3. The equipment in its installed state must not come in close proximity to any heating sources, oils, steam

WIRING GUIDELINES WARNING :

1. To prevent the risk of electric shock, power supply to the equipment must be kept OFF while doing the wiring arrangement.
2. Wiring shall be done strictly according to the terminal layout. Confirm that all connections are correct.
3. Use lugged terminals.
4. To reduce electromagnetic interference use of wires with adequate ratings and twists of the same in equal size shall be made with shortest connections.
5. Layout of connecting cables shall be away from any internal EMI source.
6. Cable used for connection to power source, must have a 220 cross section of 0.5mm to 2.5mm (20 to 14AWG; 75 C (min)).These wires shall have current carrying capacity of 6A.
7. Copper cable should be used (Stranded or Single core cable).
8. Before attempting work on device, ensure absence of voltages using appropriate voltage detection device

INSTALLATION GUIDELINES CAUTION

1. This equipment, being built-in-type, normally becomes a part of main control panel and in such case the terminals do not remain accessible to the end user after installation and internal wiring.
2. Conductors must not come in contact with the internal circuitry of the equipment or else it may lead to a safety hazard that may in turn endanger life or cause electrical shock to the operator.
3. Circuit breaker or mains switch must be installed between power source and supply terminals to facilitate power 'ON' or 'OFF' function. However this switch or breaker must be installed in a convenient position normally accessible to the operator
4. Before disconnecting the secondary of the external current transformer from the equipment, make sure that the current transformer is short circuited to avoid risk of electrical shock and injury
5. The equipment shall not be installed in environmental conditions other than those mentioned in this manual.
6. The equipment does not have a built-in-type fuse. Installation of external fuse of rating 275V AC / Amp for electrical circuitry is highly recommended.

MECHANICAL INSTALLATION

For installing the meter

1. Prepare the panel cutout with proper dimensions as shown below.
2. Push the meter into the panel cutout. Secure the meter in its place by fitting the clamp on the rear side. Fit clamps on both sides in diagonally opposite location for optimum fitting.
3. For proper sealing, tighten the screws evenly with required torque. Terminal screw tightening torque : 0.68 N-m to 0.79 N-m (6.018 In-Lb to 6.992 In-Lb) Screw clamp tightening torque : 0.1N-m (0.885 Lb-inch)

MAINTENANCE

1. The equipment should be cleaned regularly to avoid blockage of ventilating parts.
2. Clean the equipment with a clean dry or damp cloth. Do not use any cleaning agent other than water

TYPICAL WIRING DIAGRAM

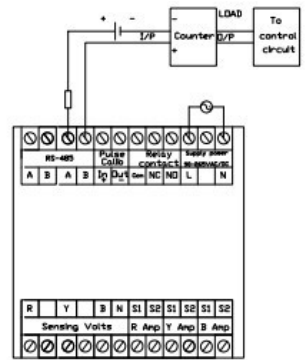
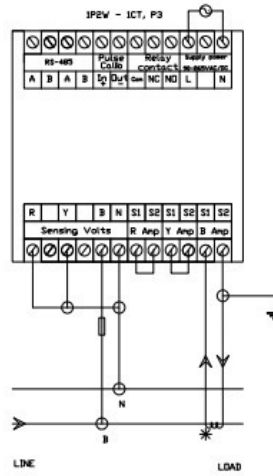
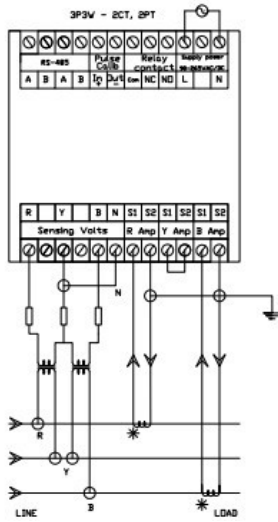
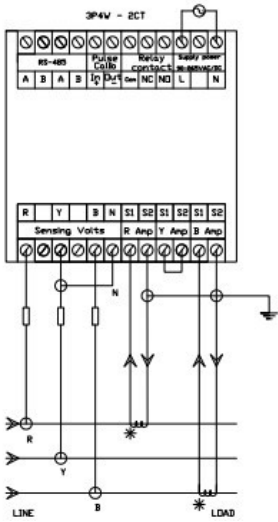
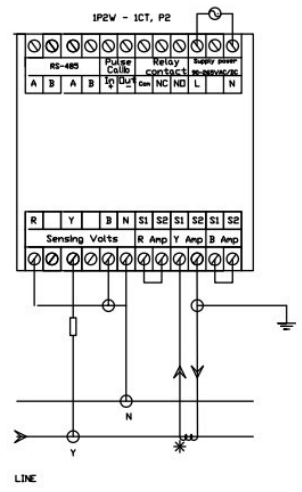
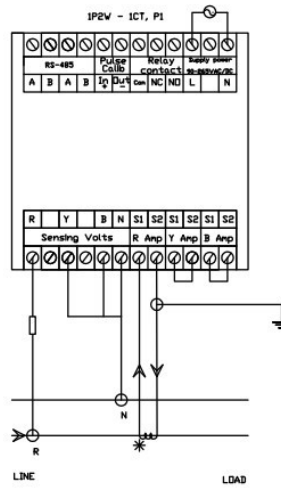
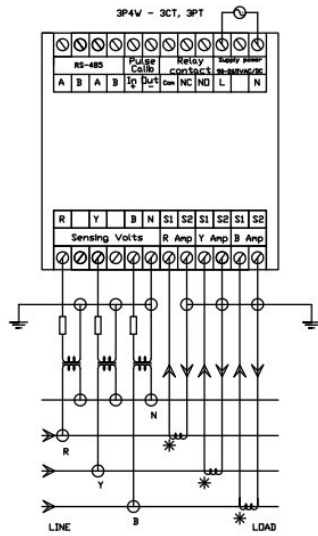
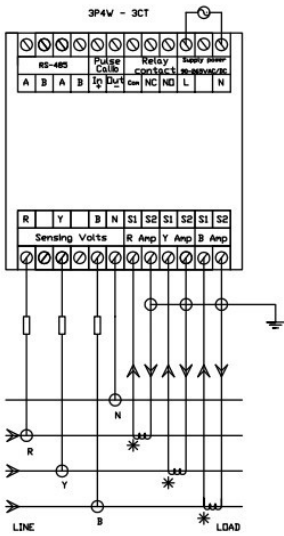

CONNECTION DIAGRAM FOR COMMUNICATION

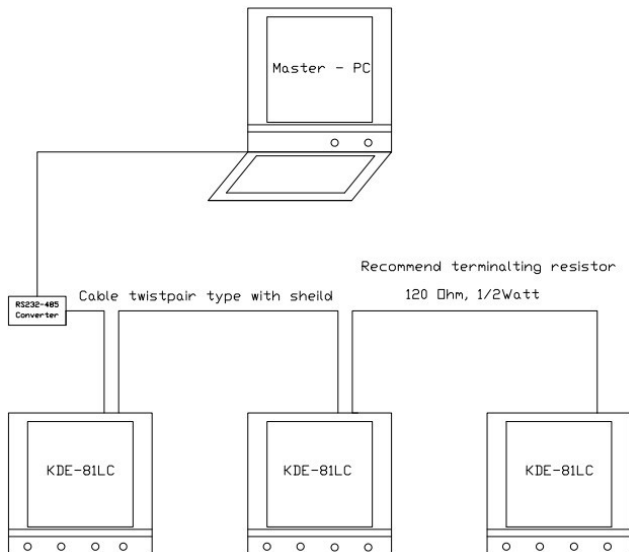

Panel cut out

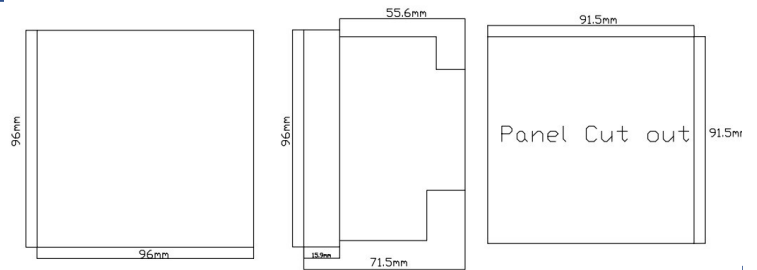

Manufacture / distributor